

Dimension drawing DG M YPV SCI 600 FM

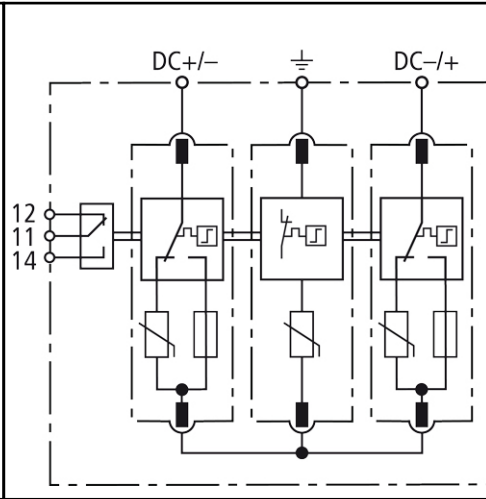

Basic circuit diagram DG M YPV SCI 600 FM



DG M YPV SCI 600 (FM): Multipole modular surge arrester with 3-step d.c. switching device for use in PV systems up to 600 V; optionally available with remote signalling contact for monitoring device (floating changeover contact)

- **Prewired modular complete unit for use in photovoltaic systems consisting of a base part and plug-in protection modules**
- **Combined disconnection and short-circuiting device with safe electrical isolation in the protection module prevents fire damage due to d.c. arcs**
- **Tried and tested fault-resistant Y circuit prevents damage to the surge protective devices in case of insulation faults in the generator circuit**
- **Safe replacement of protection modules without arc formation due to integrated d.c. fuse**

DG M YPV SCI 600

SPD according to EN 61643-11	Type 2
SPD according to IEC 61643-1	Class II
Max. PV voltage [U _{PVmax}]	≤ 600 V
Total discharge current (8/20 μs) [I _{total}]	40 kA
Nominal discharge current (8/20 μs) [(DC+/DC-) → PE] [I _n]	12.5 kA
Max. discharge current (8/20 μs) [(DC+/DC-) → PE] [I _{max}]	25 kA
Voltage protection level [U _p]	≤ 2.5 kV
Voltage protection level for 5 kA [U _p]	≤ 2 kV
Response time [t _A]	≤ 25 ns
Operating temperature range [T _U]	-40°C...+80°C
Breaking capacity of the internal fuse	30 kA / 1000 V d.c.
Operating state/fault indication	green / red
Cross-sectional area (min.)	1.5 mm ² solid/flexible
Cross-sectional area (max.)	35 mm ² stranded/25 mm ² flexible
For mounting on	35 mm DIN rail acc. to EN 60715
Enclosure material	thermoplastic, red, UL 94 V-0
Degree of protection	IP 20
Dimension	3 mod(s)., DIN 43880
	1 pc(s).

Ordering information

Type	DG M YPV SCI 600
Part No.	952 511
Packing unit	

We reserve the right to modify design, technology, dimensions, weights and materials according to technical progress. Illustrations are non-binding. Pictures may differ from the modules described.